



Installation instructions, accessories

Volvo Car Corporation Gothenburg, Sweden

Instruction No	Version	Part. No.
31428068	1.0	31414813, 31439261

Sill molding, illuminated, rear



Installation instructions, accessories

Volvo Car Corporation Gothenburg, Sweden

Special tools

	999 5919 PULLER (SEAL-PINION,CAM-CRANKSHAFT)B200-6304 Tool number:999 5919 Tool description:PULLER (SEAL-PINION,CAM-CRANKSHAFT)B200-6304 Tool boards:46
	951 2932 Tension spring Tool number:951 2932 Tool description:Tension spring Tool boards:80

Equipment

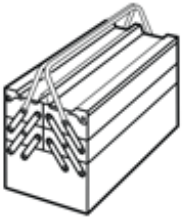

A0000162



Installation instructions, accessories

Volvo Car Corporation Gothenburg, Sweden

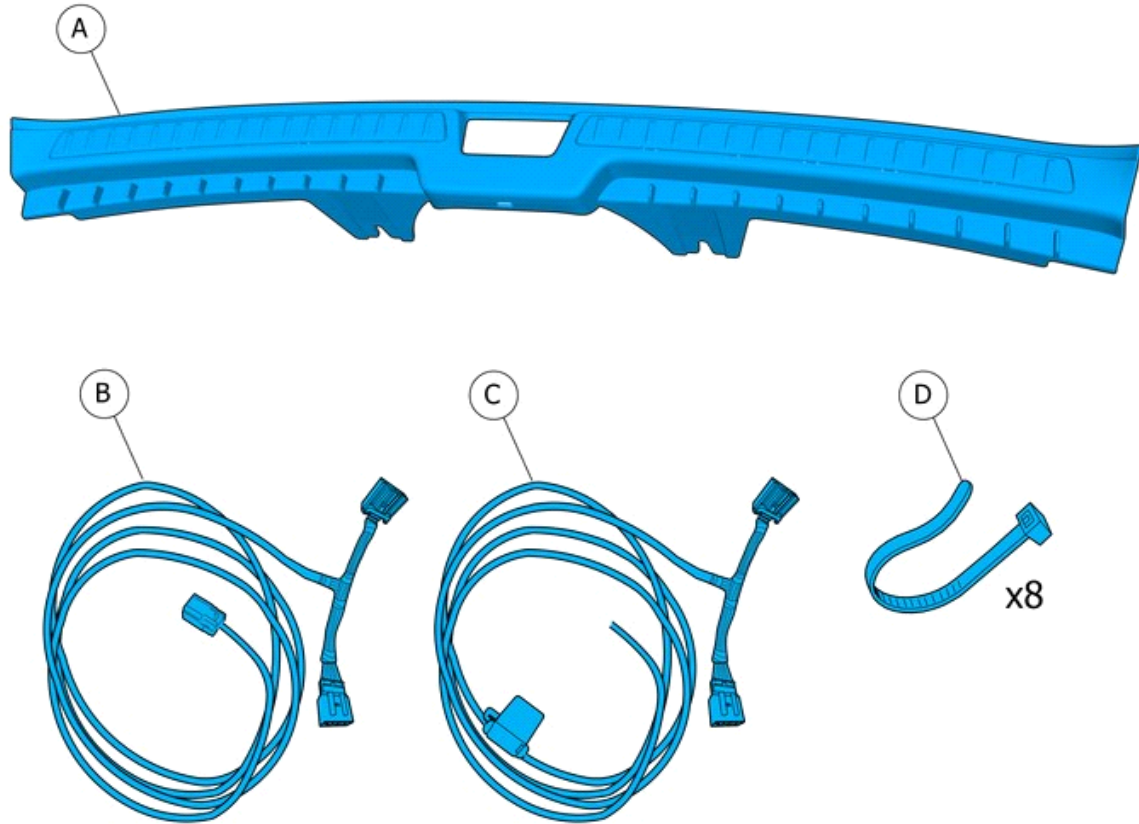

IMG-394812



Installation instructions, accessories

Volvo Car Corporation Gothenburg, Sweden

Information

1

Read through all of the instructions before starting installation.

Notifications and warning texts are for your safety and to minimise the risk of something breaking during installation.

Ensure that all tools stated in the instructions are available before starting installation.

Certain steps in the instructions are only presented in the form of images. Explanatory text is also given for more complicated steps.

In the event of any problems with the instructions or the accessory, contact your local Volvo dealer.

Color symbols

2

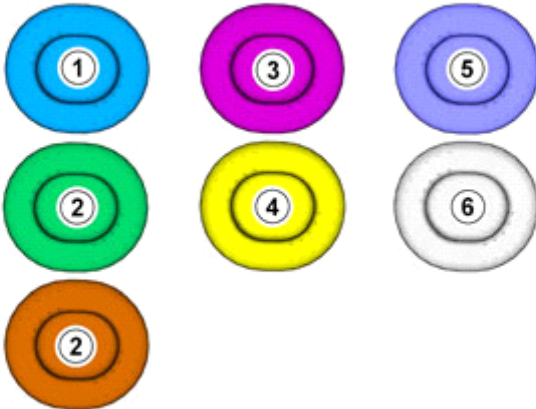

IMG-363036

Note!

This colour chart displays (in colour print and electronic version) the importance of the different colours used in the images of the method steps.

1. Used for focused component, the component with which you will do something.
2. Used as extra colors when you need to show or differentiate additional parts.
3. Used for attachments that are to be removed/installed. May be screws, clips, connectors, etc.
4. Used when the component is not fully removed from the vehicle but only hung to the side.
5. Used for standard tools and special tools.
6. Used as background color for vehicle components.

Removal



Installation instructions, accessories

Volvo Car Corporation Gothenburg, Sweden

3

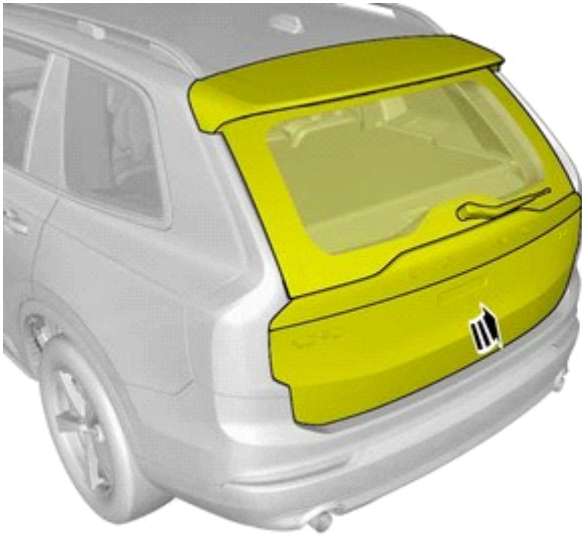

IMG-394779

4

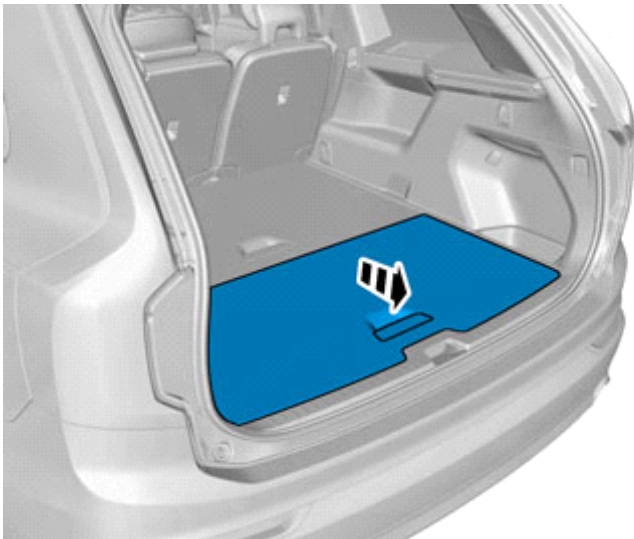

IMG-383040

5



IMG-394727



Installation instructions, accessories

Volvo Car Corporation Gothenburg, Sweden

6

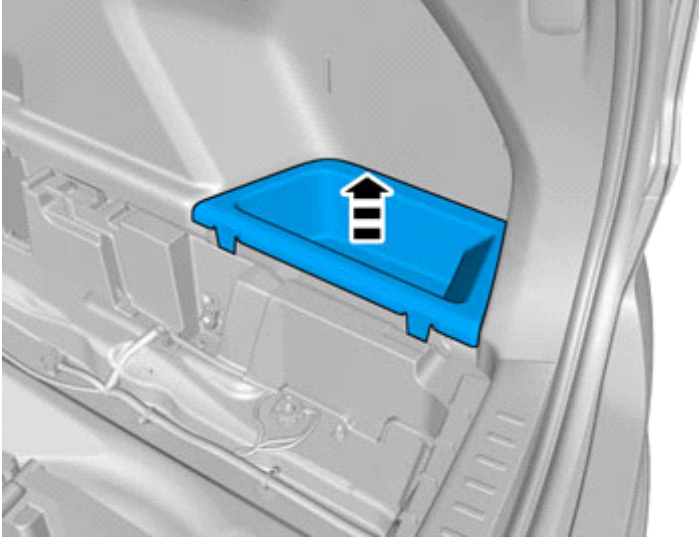

IMG-383066

7

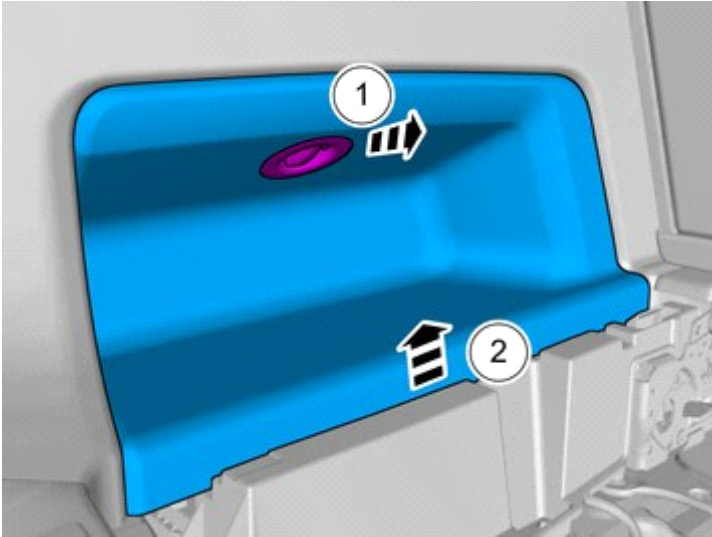

IMG-387004

Remove the marked part.

8

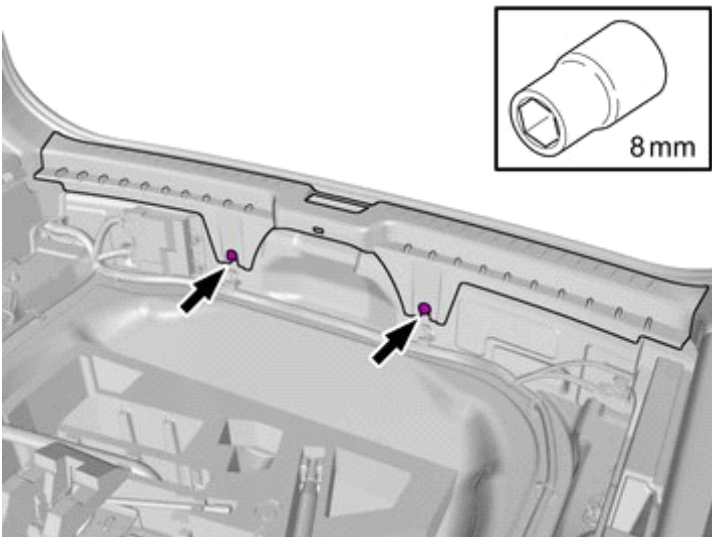

IMG-383047

Note!
Do not loosen the bolts more than 2 turns.



Installation instructions, accessories

Volvo Car Corporation Gothenburg, Sweden

9

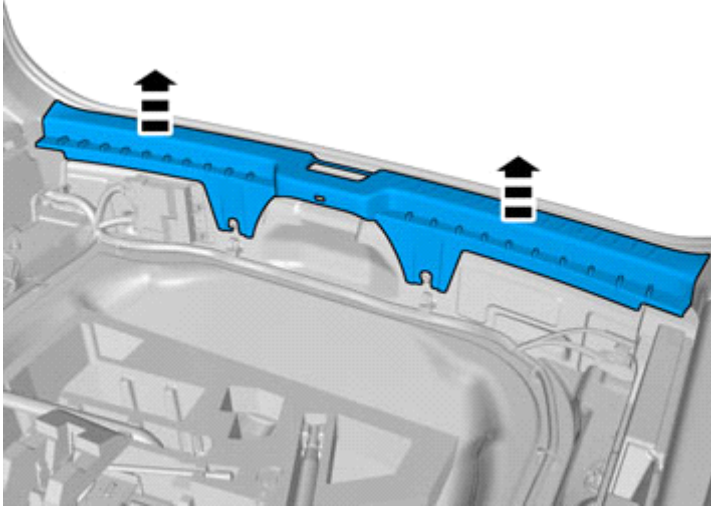

IMG-383048

Note!

The clips consist of two parts.

The part is not to be reused.

10

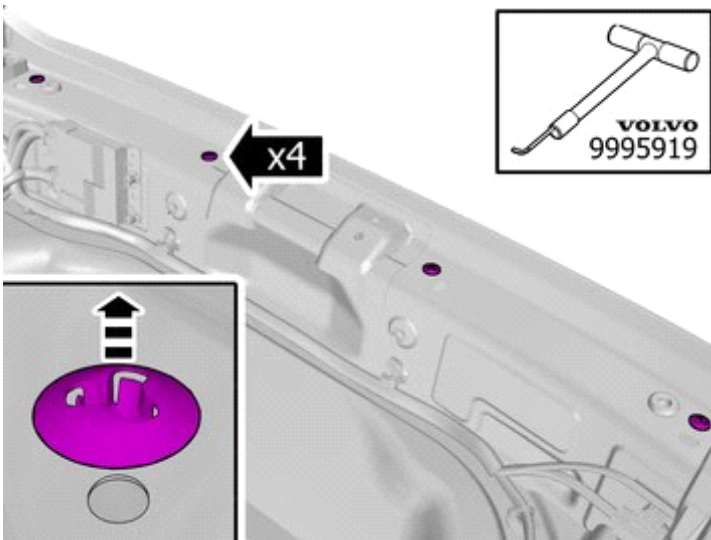

IMG-393950

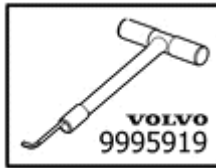

Remove the clips.

Use special tool: T9995919, PULLER (SEAL-PINION,CAM-CRANKSHAFT)B200-6304



Installation instructions, accessories

Volvo Car Corporation Gothenburg, Sweden

11

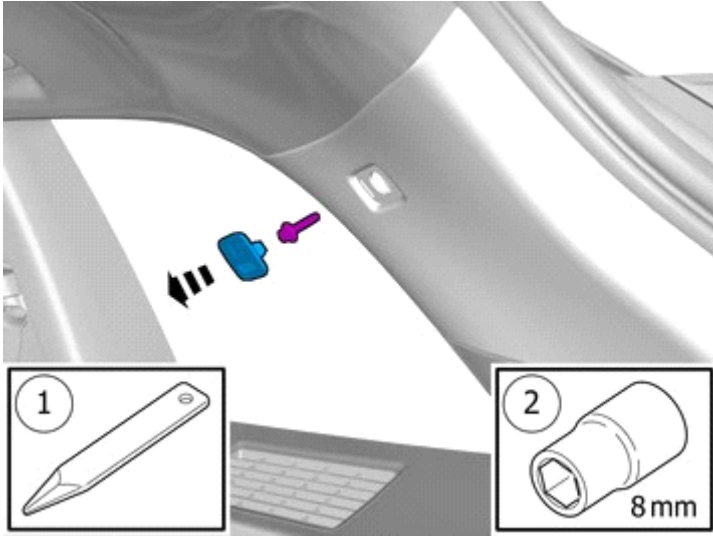

IMG-383043

Repeat on the other side.

12

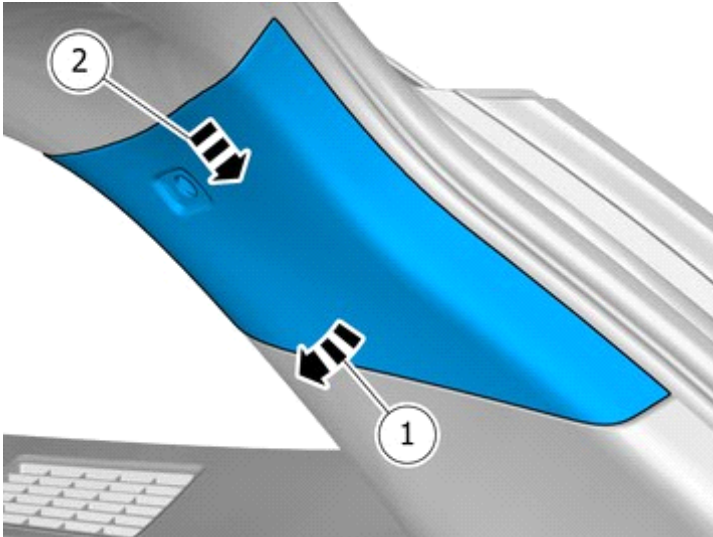

IMG-383044

Remove the panel.

Repeat on the other side.

13

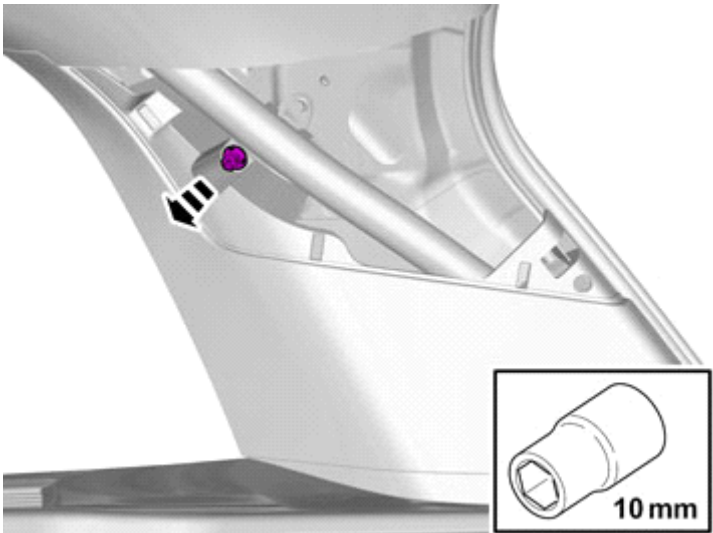

IMG-383045

Remove the nut.

Repeat on the other side.



Installation instructions, accessories

Volvo Car Corporation Gothenburg, Sweden

14

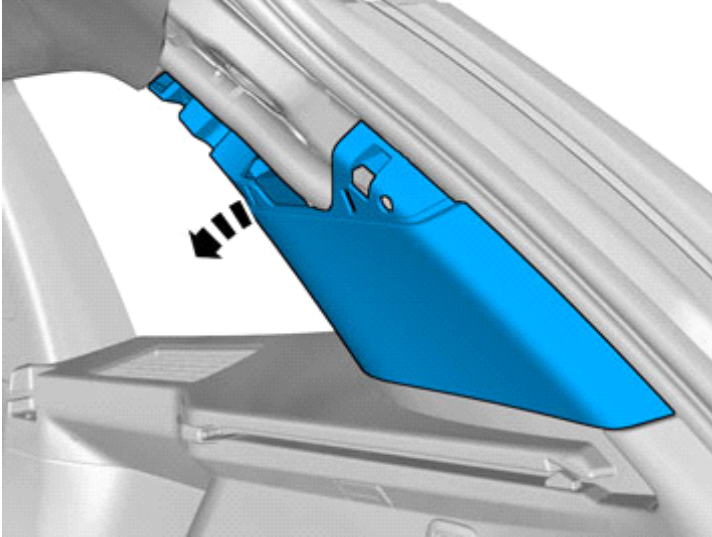

IMG-383046

Remove the panel.

Repeat on the other side.

Accessory installation

15

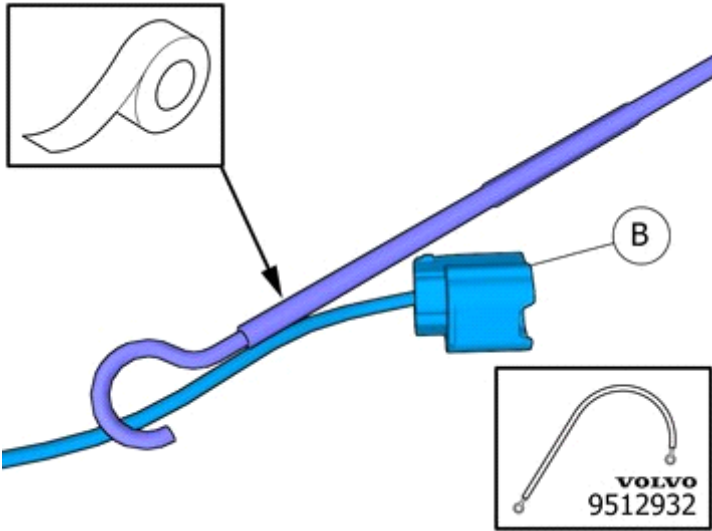

IMG-394786

Use special tool: T9512932, Tension spring



Installation instructions, accessories

Volvo Car Corporation Gothenburg, Sweden

16

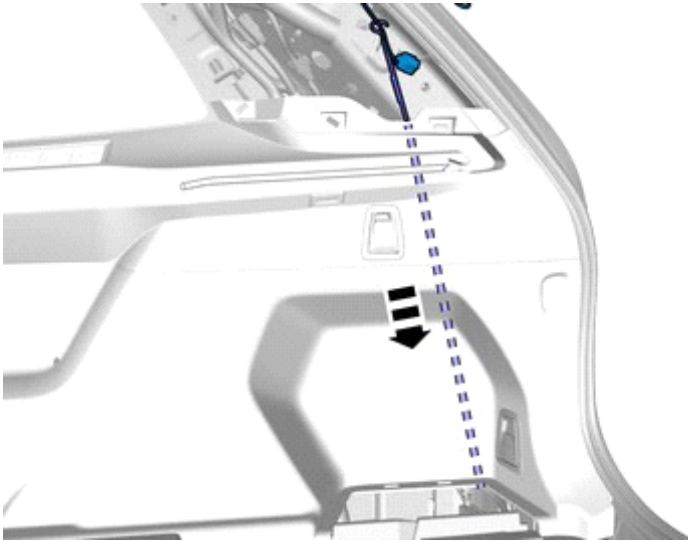

IMG-394795

Pull the wiring through.

Remove the tool.

17

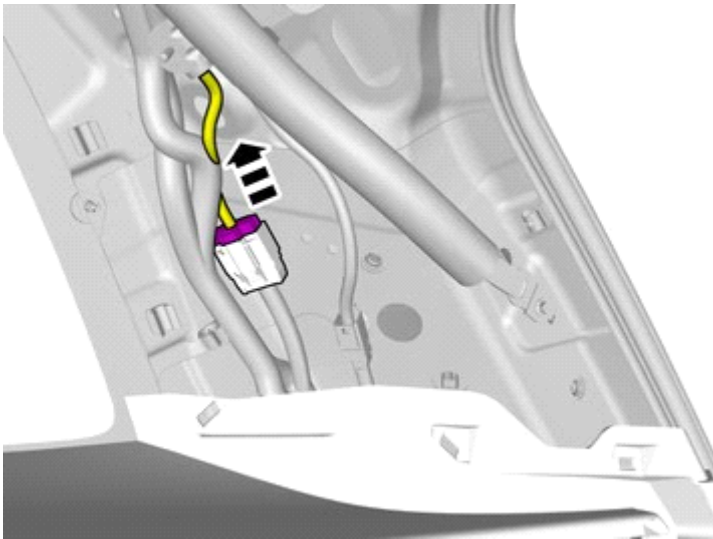

IMG-394731

Disconnect the connector.

18

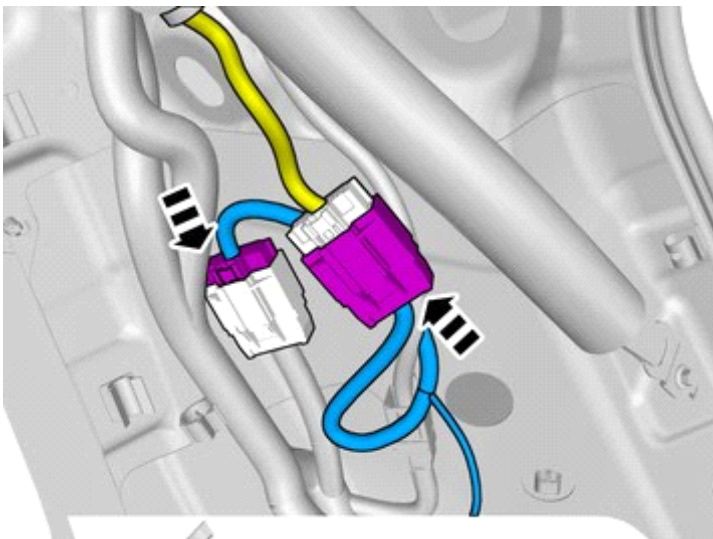

IMG-394736

Connect the connectors.



Installation instructions, accessories

Volvo Car Corporation Gothenburg, Sweden

19

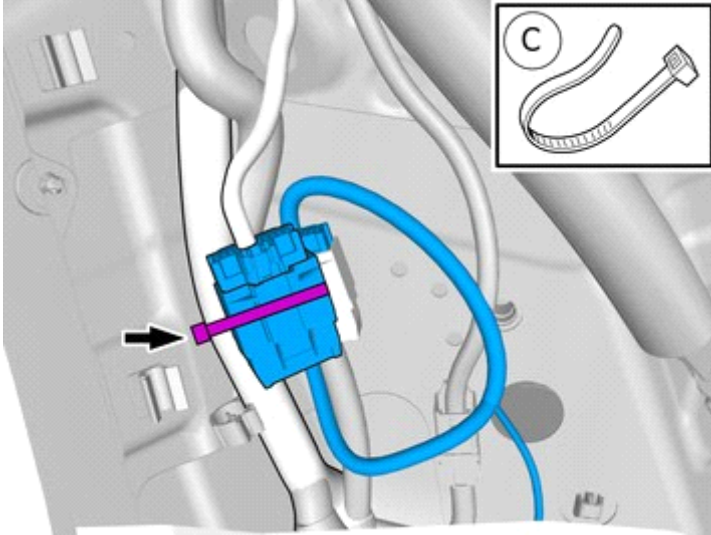

IMG-394742

Attach the connector to the wiring harness.

20

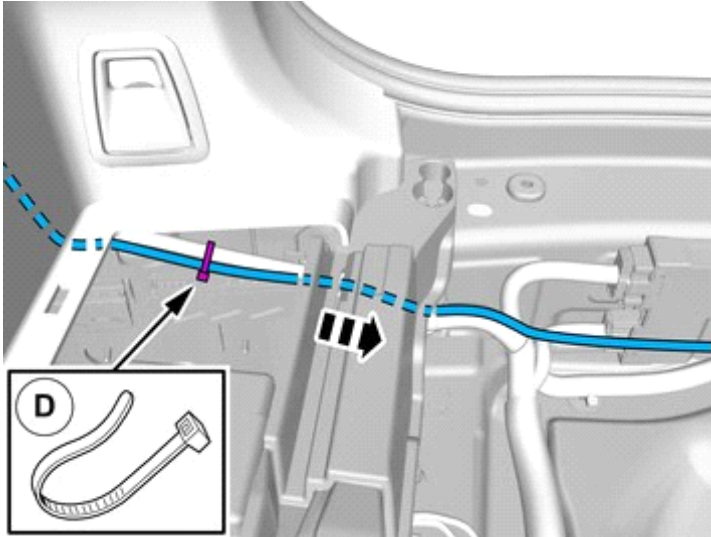

IMG-401498

Pull the wiring through.

Route the wire adjacent to existing wirings.

Install the cable.

Use a cable tie

21

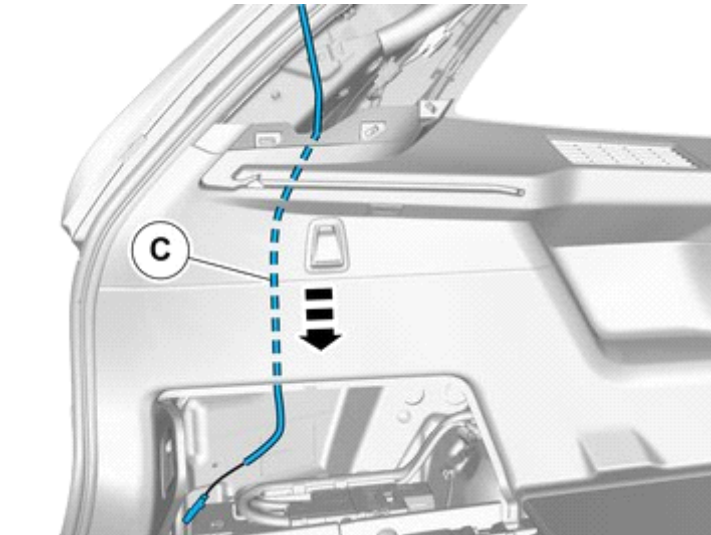

IMG-401516

Pull the wiring through.



Installation instructions, accessories

Volvo Car Corporation Gothenburg, Sweden

22

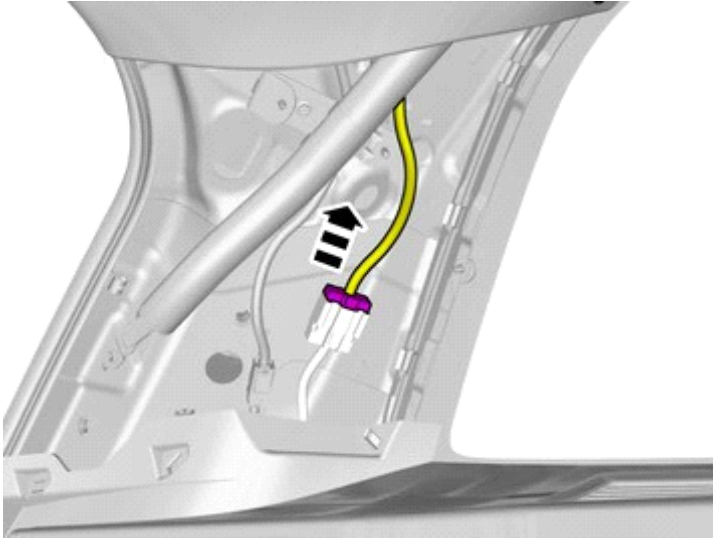

IMG-401509

Disconnect the connector.

23

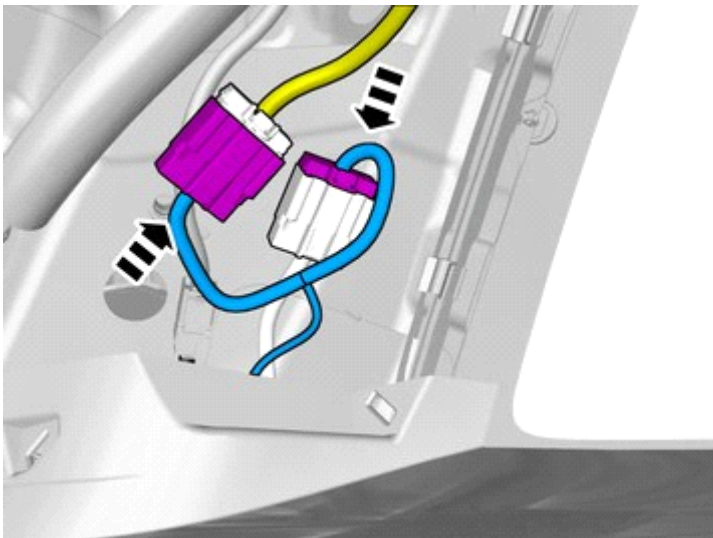

IMG-401508

Connect the connectors.



Installation instructions, accessories

Volvo Car Corporation Gothenburg, Sweden

24

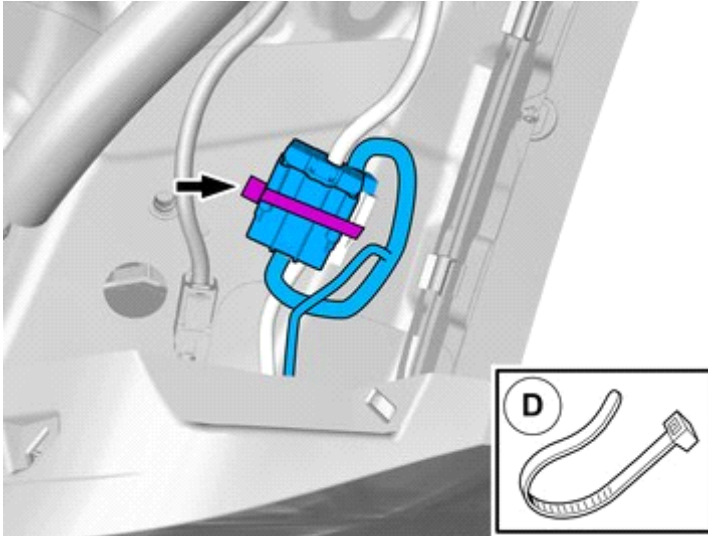

IMG-401507

Attach the connector to the wiring harness.

25

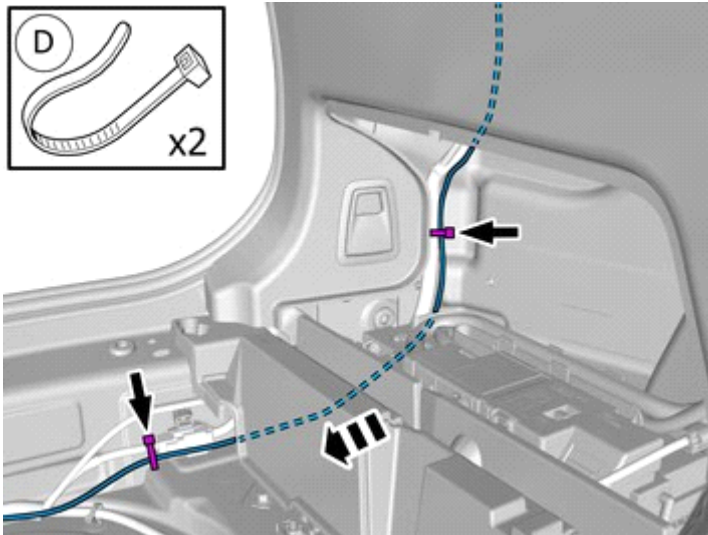

IMG-403005

Route the wire adjacent to existing wirings.

Install the cable.

Use a cable tie

26

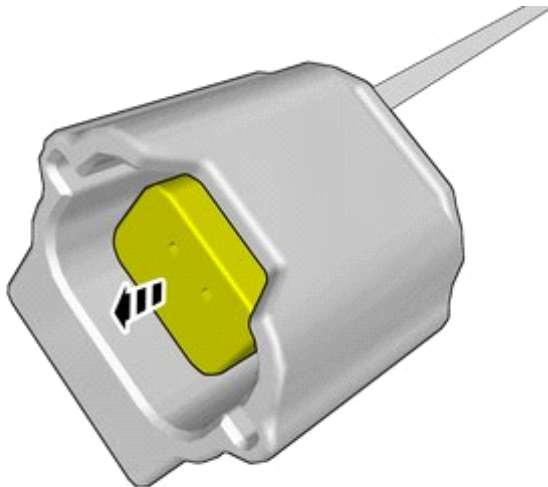

IMG-403003

Release the connector's secondary lock.

Lift approximately 2 mm.



Installation instructions, accessories

Volvo Car Corporation Gothenburg, Sweden

27

Connect the prerouted cable.

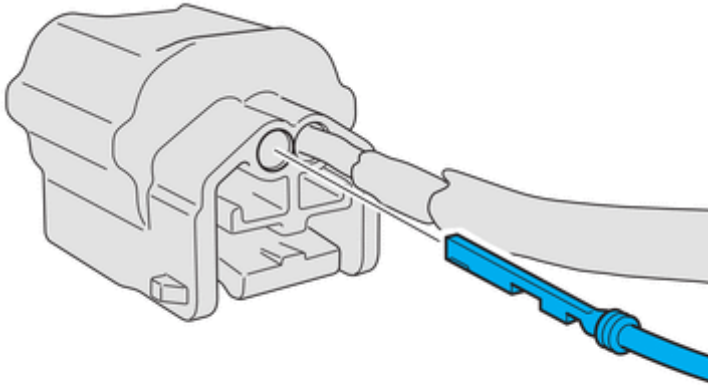

IMG-403042

28

Depress the secondary lock.

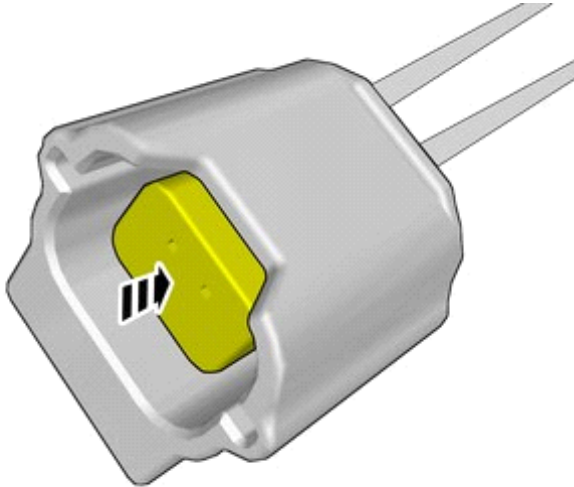

IMG-403004

29

Connect the connector.

Install the cables.

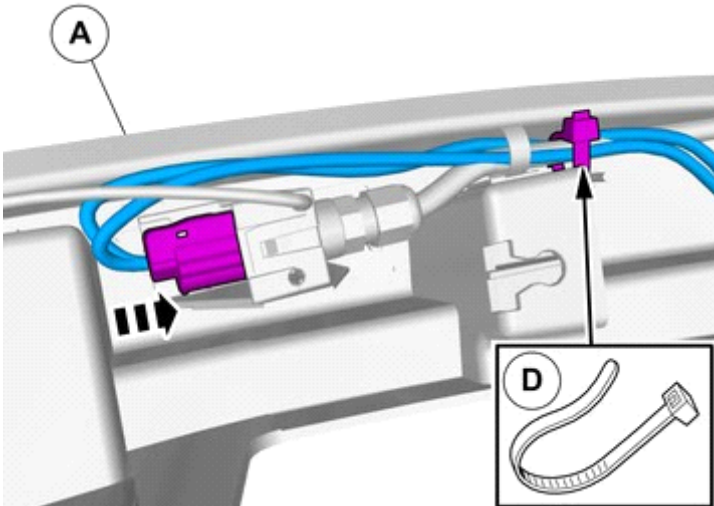

IMG-401480



Installation instructions, accessories

Volvo Car Corporation Gothenburg, Sweden

30

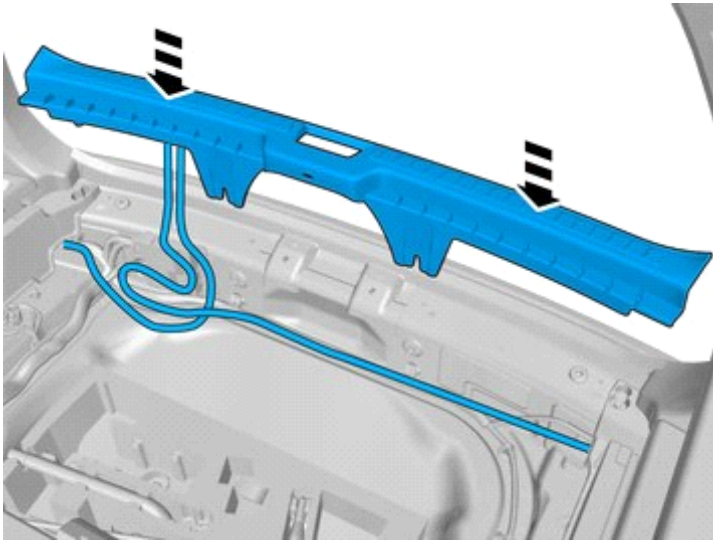

IMG-394814

31

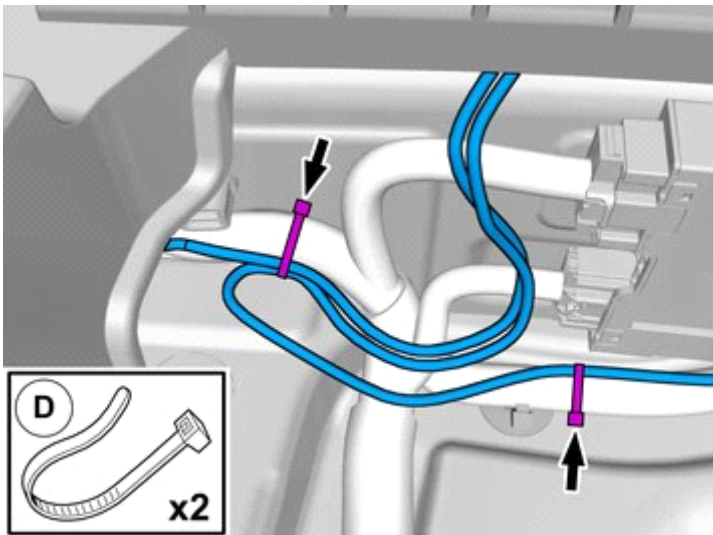

IMG-401492

Position the cable harness excess as illustrated.

Install the cables.

Use a cable tie



Installation instructions, accessories

Volvo Car Corporation Gothenburg, Sweden

32

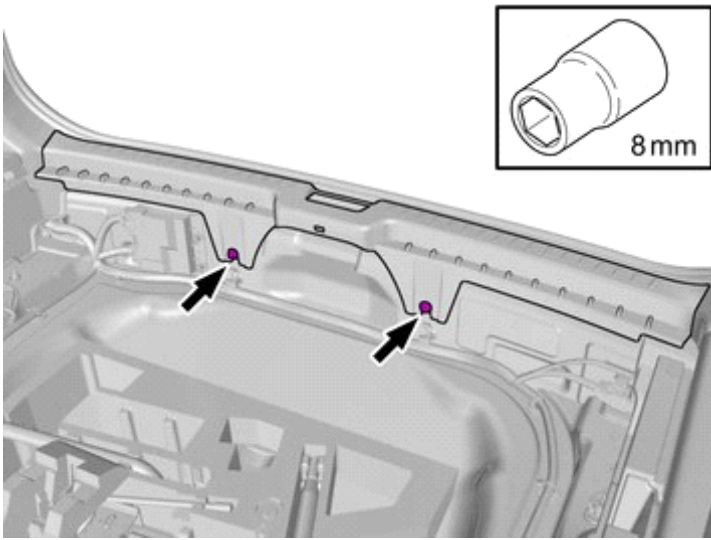

IMG-383047

Tighten the bolts.

Installation

33

Reinstall the removed parts in reverse order.
